

REVISIONS				
ZONE	REV.	DESCRIPTION	DATE	APPROVED

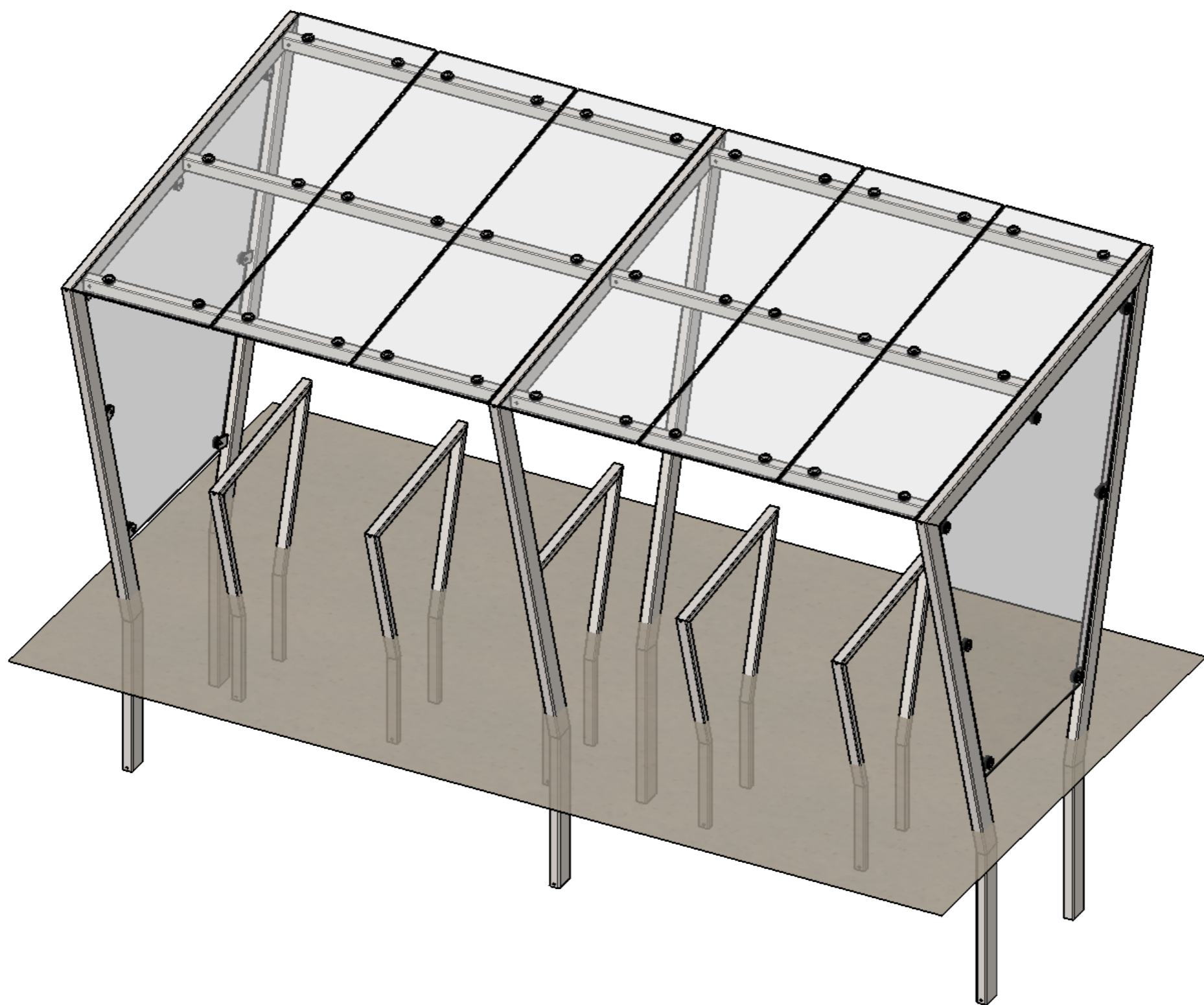

DELIVERY ADRESSE:

ROOF COVER:  
Szkło VSG/ESG 4.4.2 - SAWO

WALL INFILL:  
Szkło ESG 8 mm - SAWO

LOADINGS:  
Obciążenie śniegiem  
 $s_k=0,9 \text{ kN/m}^2$

Obciążenie wiatrem  
 $v_{b,0}=22 \text{ m/s}$

COATING: HDG, EN-ISO 1461 ;



ul. Dąbrowskiego 247/249  
93-231 Łódź  
Polska

tel: (+48) 42 670-75-55  
Fax: (+48) 42 670-81-80  
e-mail: sawo@sawo.com.pl

Proj.  Name

Scale  
1:25

**WIDOK 3D**

Drawn by  
**H.Hofer**  
30.04.2021

Verified by  
**SAWO**  
30.04.2021

Approved by  
-

Date  
30.04.2021

Tolerances:  
acc. to ISO 13920 DH

Drawing number

Unit  
mm

Size  
A3

Rev  
0

Sheet  
1/10

**HOL**

HOL\_CONC\_r-00

8

7

6

5

4

3

2

1

F

E

D

C

B

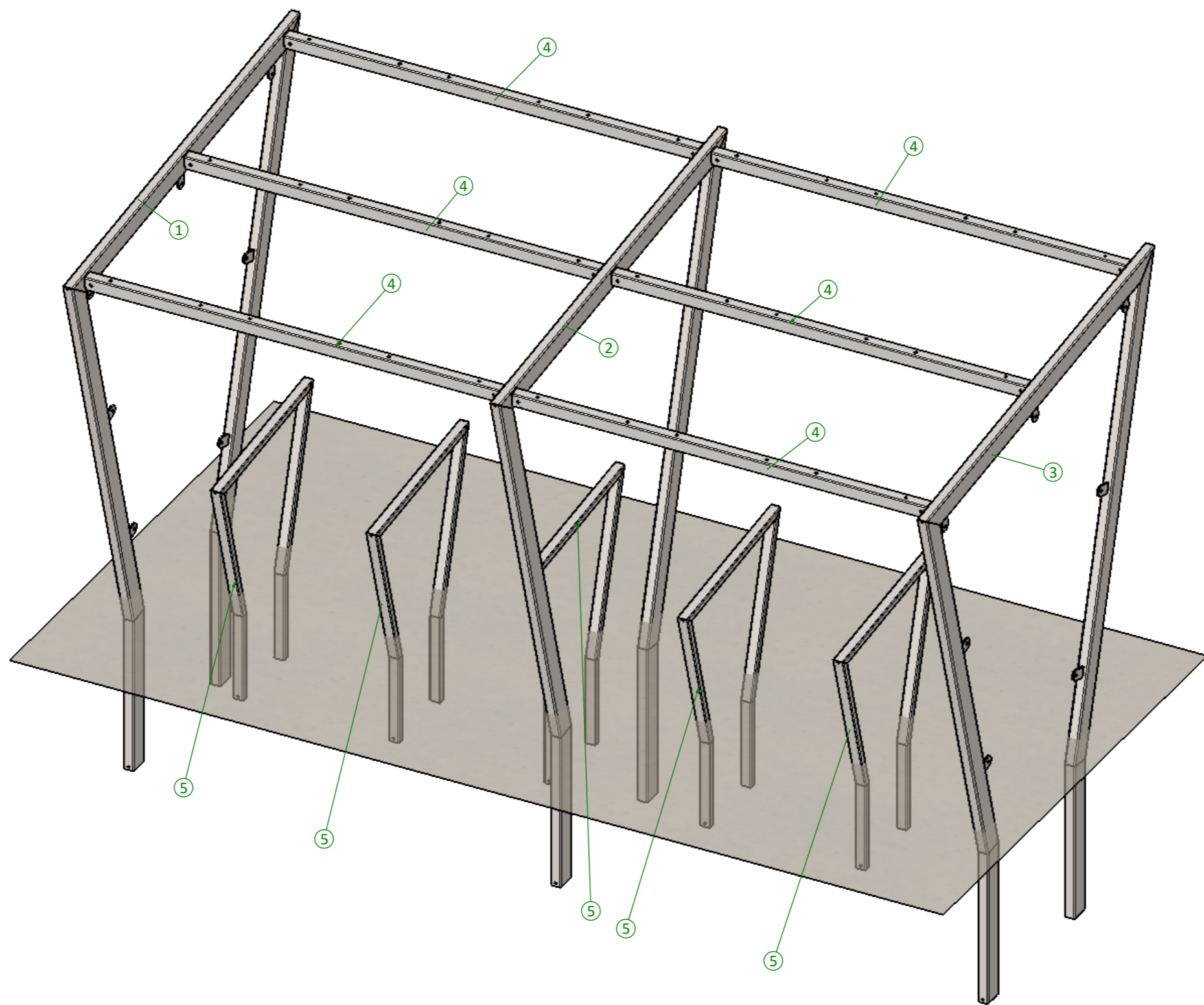

A

NR	NAZWA	OPIS	ILOŚĆ
1	RAMA LEWA	RHS 120 x 60 x 4	1
2	RAMA ŚRODKOWA	RHS 120 x 60 x 4	1
3	RAMA PRAWA	RHS 120 x 60 x 4	1
4	BELKA DACHOWA	RHS 80 x 60 x 3	6
5	STOJAK ROWEROWY - 2 rowery	RHS 60 x 40 x 3	5

8

7

6

5



4

3

2

1

A

-		COATING: HDG, EN-ISO 1461 ;		
 ul. Dąbrowskiego 247/249 93-231 Łódź Polska tel: (+48) 42 670-75-55 Fax: (+48) 42 670-81-80 e-mail: sawo@sawo.com.pl		Drawn by <b>H.Hofer</b> 30.04.2021	Verified by <b>SAWO</b> 30.04.2021	Approved by - - Date 30.04.2021
		Tolerances: acc. to ISO 13920 DH		Drawing number
Proj.  Scale 1:25	<b>KONSTRUKCJA</b>		<b>HOL</b>	
		Unit mm Rev 0	Size A3 Sheet 2/10	

HOL\_CONC\_r-00

8

7

6

5

4

3

2

1

F

E

D

C

B

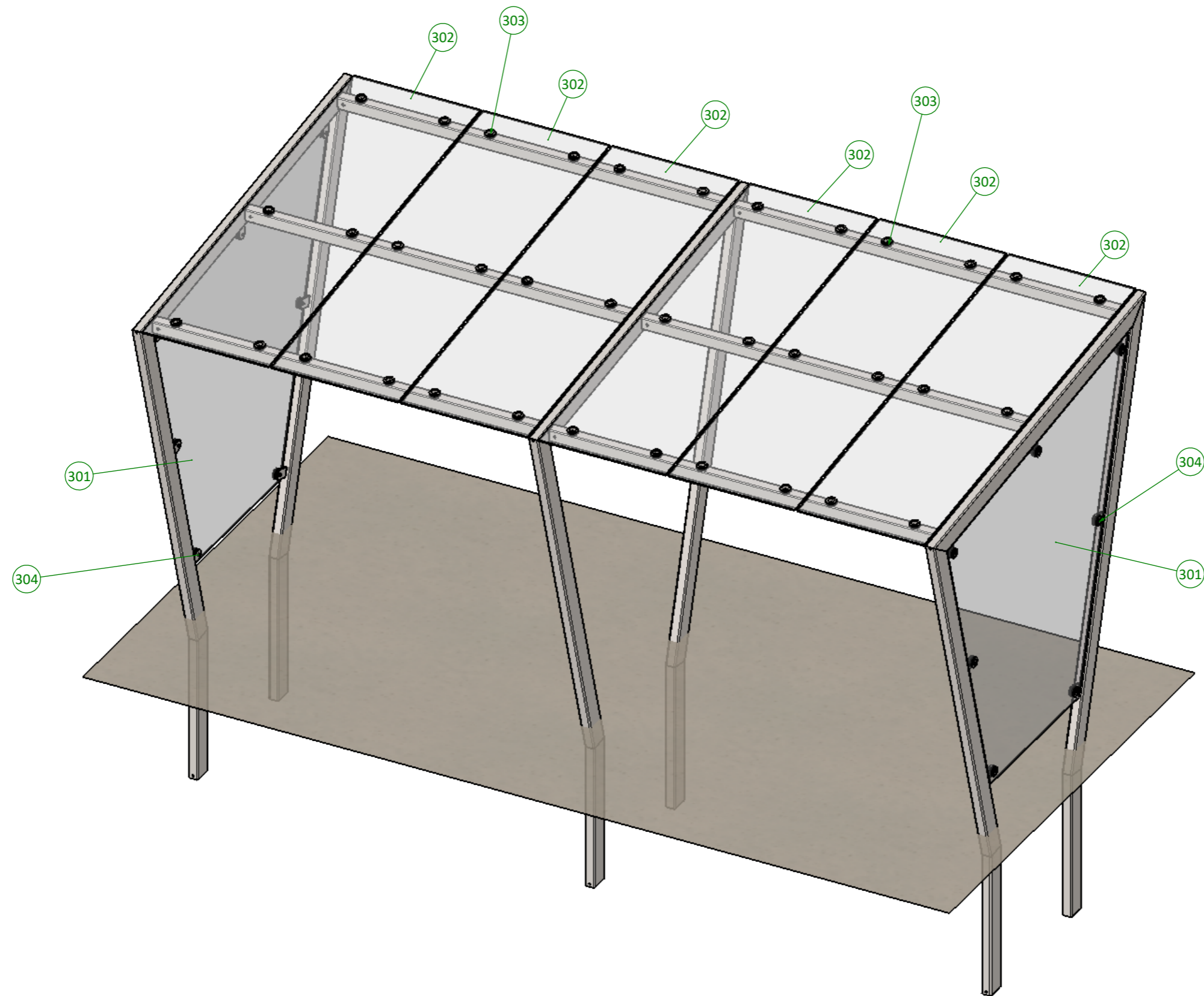

A

NR	NAZWA	OPIS	ILOŚĆ
301	SZKŁO ŚCIANA	Sztko ESG 8 mm	2
302	SZKŁO POŁAĆ	Sztko VSG/ESG 4.4.2	6
303	UCHWYT DO SZKŁA	UCHWYT $\varnothing$ 60 AISI 304 M10	36
304	UCHWYT DO SZKŁA	UCHWYT $\varnothing$ 60 AISI 304 M12	14

8

7

6



5

4

3

2



1

-		COATING: HDG, EN-ISO 1461 ;		
 ul. Dąbrowskiego 247/249 93-231 Łódź Polska Proj.  Name Scale 1:25		Drawn by <b>H.Hofer</b> 30.04.2021	Verified by <b>SAWO</b> 30.04.2021	Approved by - - Date 30.04.2021
		Tolerances: acc. to ISO 13920 DH		Drawing number <b>HOL</b>
<b>SZKŁO + UCHWYTY</b>		<b>HOL</b>		

HOL\_CONC\_r-00

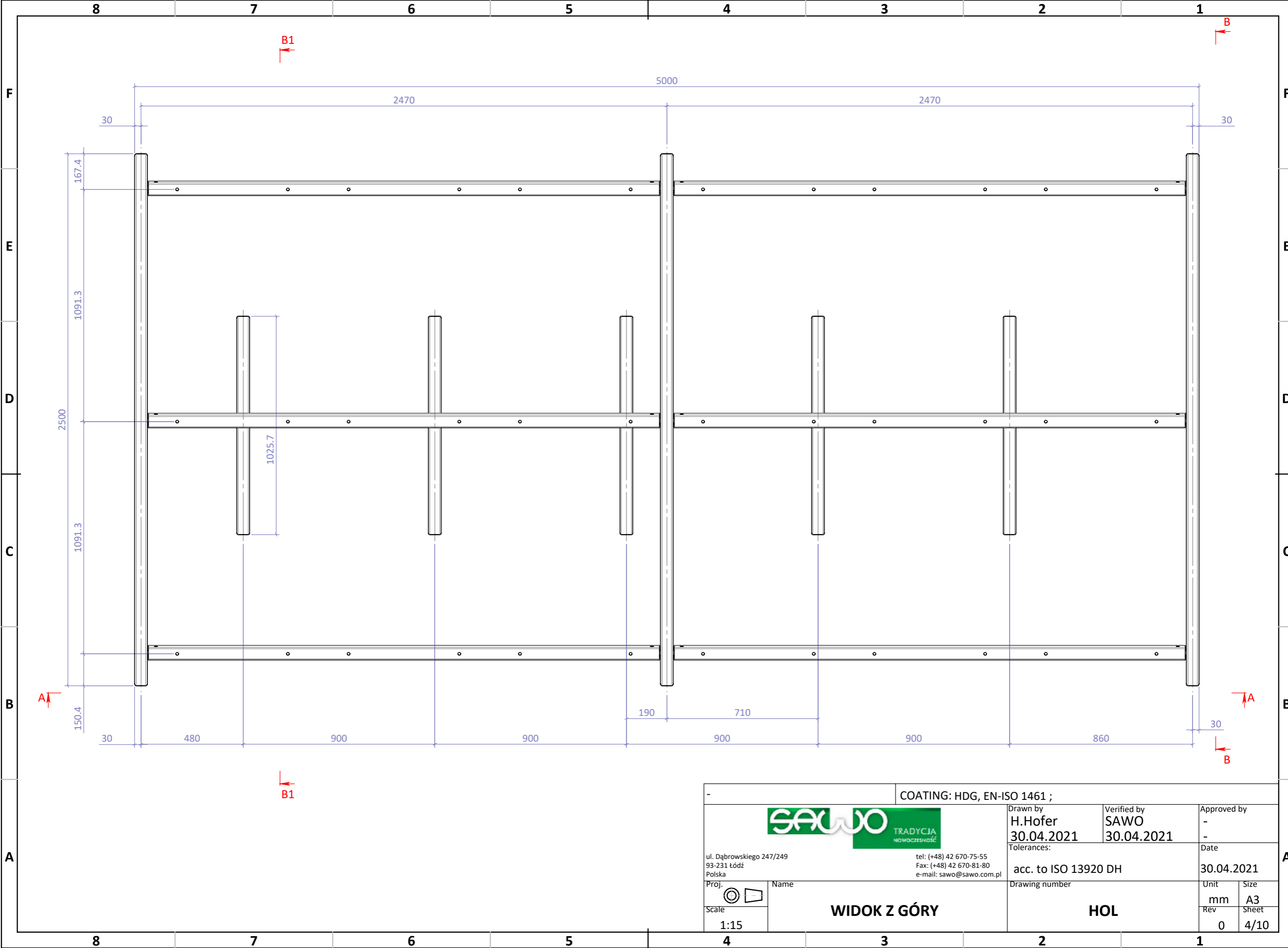
A



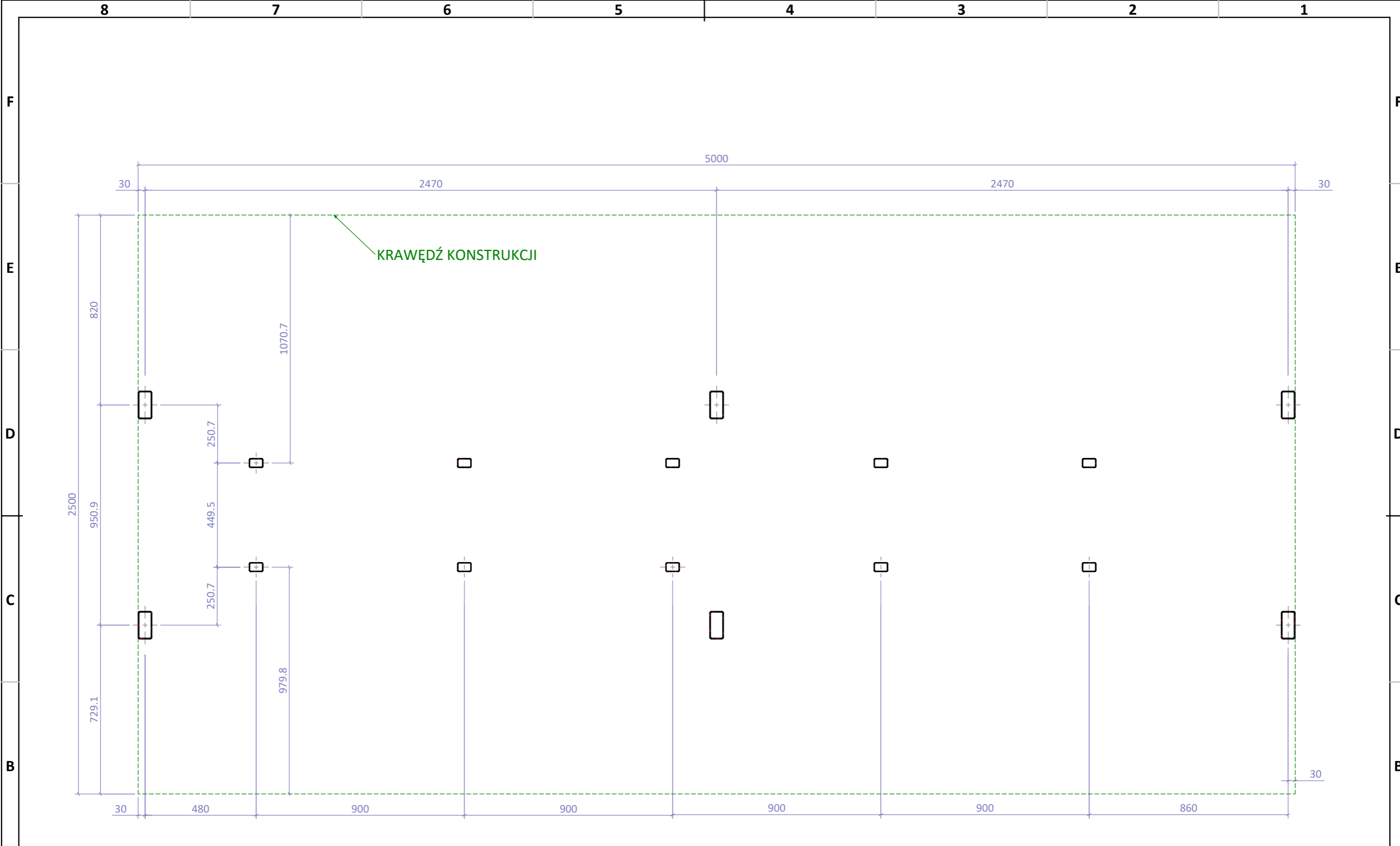

-		COATING: HDG, EN-ISO 1461 ;		
 ul. Dąbrowskiego 247/249 93-231 Łódź Polska tel: (+48) 42 670-75-55 Fax: (+48) 42 670-81-80 e-mail: sawo@sawo.com.pl		Drawn by <b>H.Hofer</b> 30.04.2021	Verified by <b>SAWO</b> 30.04.2021	Approved by -
		Tolerances: acc. to ISO 13920 DH		Date 30.04.2021
Proj. 	Name	Drawing number		
Scale 1:15	<b>WIDOK Z GÓRY</b>	<b>HOL</b>		
		Unit mm	Size A3	
		Rev 0	Sheet 4/10	

HOL\_CONC\_r-00



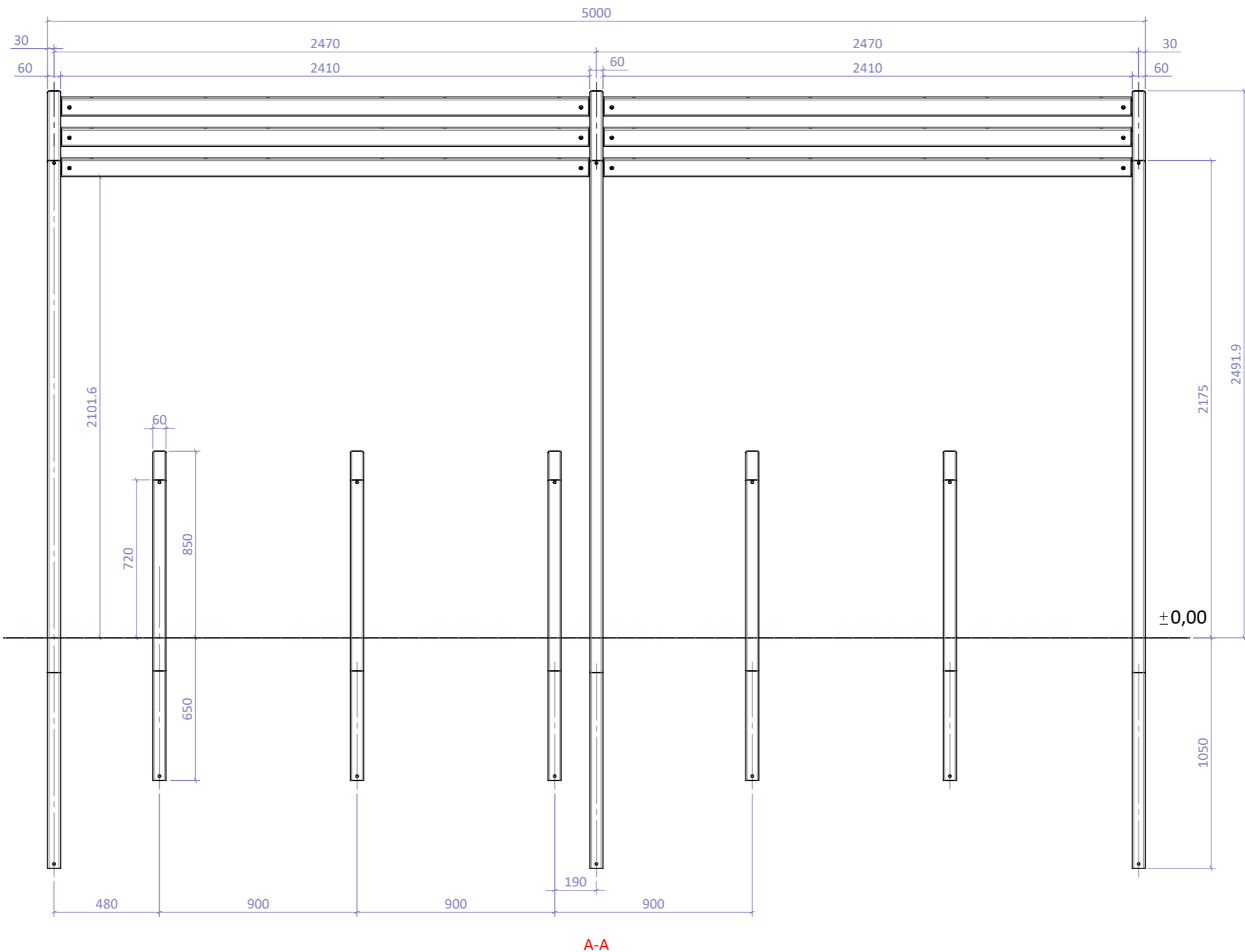

HOL\_CONC\_r-00

-		COATING: HDG, EN-ISO 1461 ;		
 ul. Dąbrowskiego 247/249 93-231 Łódź Polska tel: (+48) 42 670-75-55 Fax: (+48) 42 670-81-80 e-mail: sawo@sawo.com.pl		Drawn by <b>H.Hofer</b> 30.04.2021	Verified by <b>SAWO</b> 30.04.2021	Approved by - - Date 30.04.2021
		Tolerances: acc. to ISO 13920 DH		Drawing number <b>HOL</b>
Proj. 	Name <b>PLAN POSADOWIENIA</b>	Unit mm	Size A3	
Scale 1:15		Rev 0	Sheet 5/10	



A-A

-		COATING: HDG, EN-ISO 1461 ;	
		Drawn by <b>H.Hofer</b> 30.04.2021	Verified by <b>SAWO</b> 30.04.2021
		Tolerances: acc. to ISO 13920 DH	
ul. Dąbrowskiego 247/249 93-231 Łódź Polska Proj.  Name Scale 1:20		tel: (+48) 42 670-75-55 Fax: (+48) 42 670-81-80 e-mail: sawo@sawo.com.pl Drawing number <b>HOL</b>	
<b>WIDOK A</b>		Approved by - - Date 30.04.2021 Unit mm Rev 0	
		Size A3 Sheet 6/10	

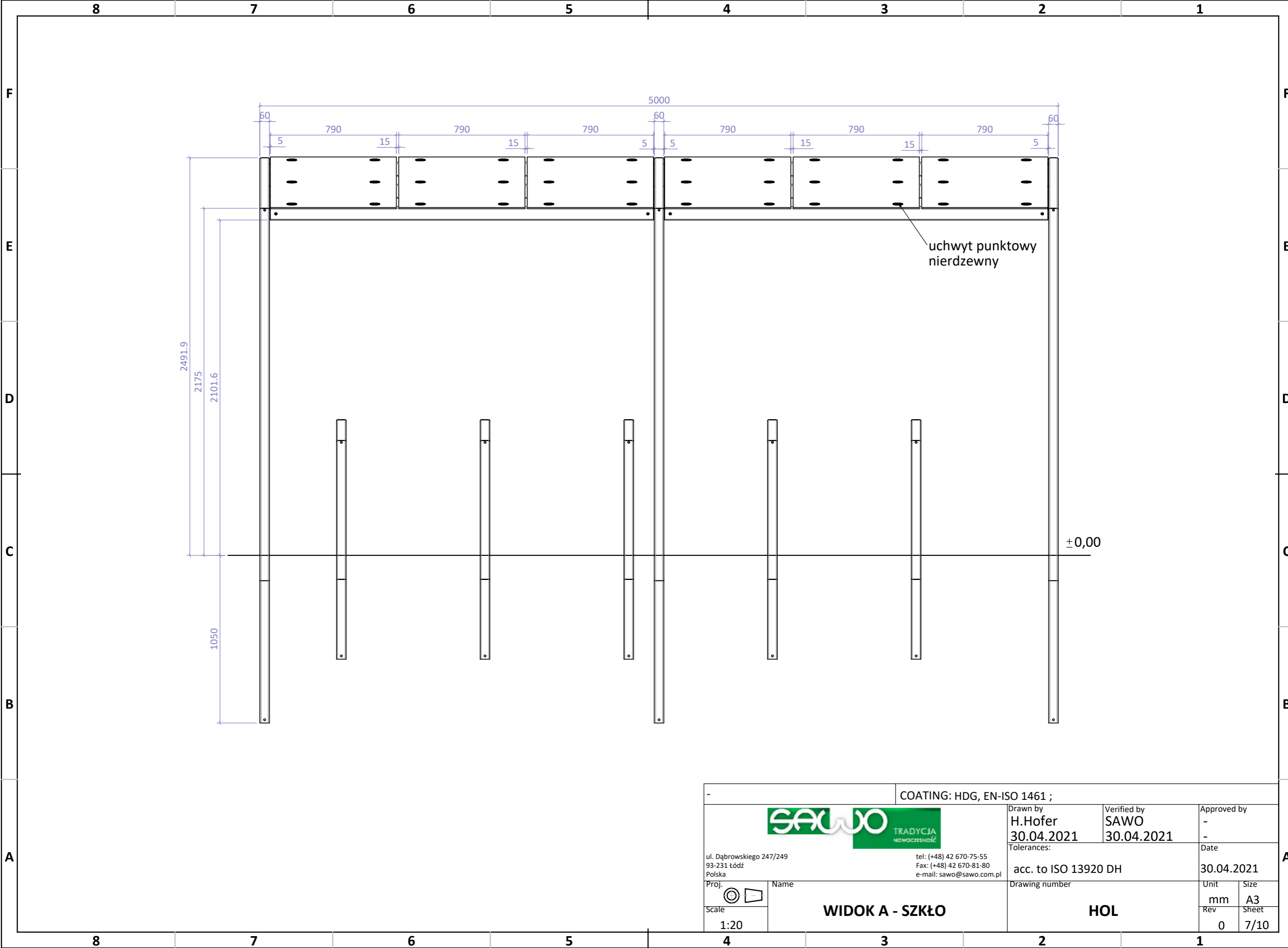

HOL\_CONC\_r-00

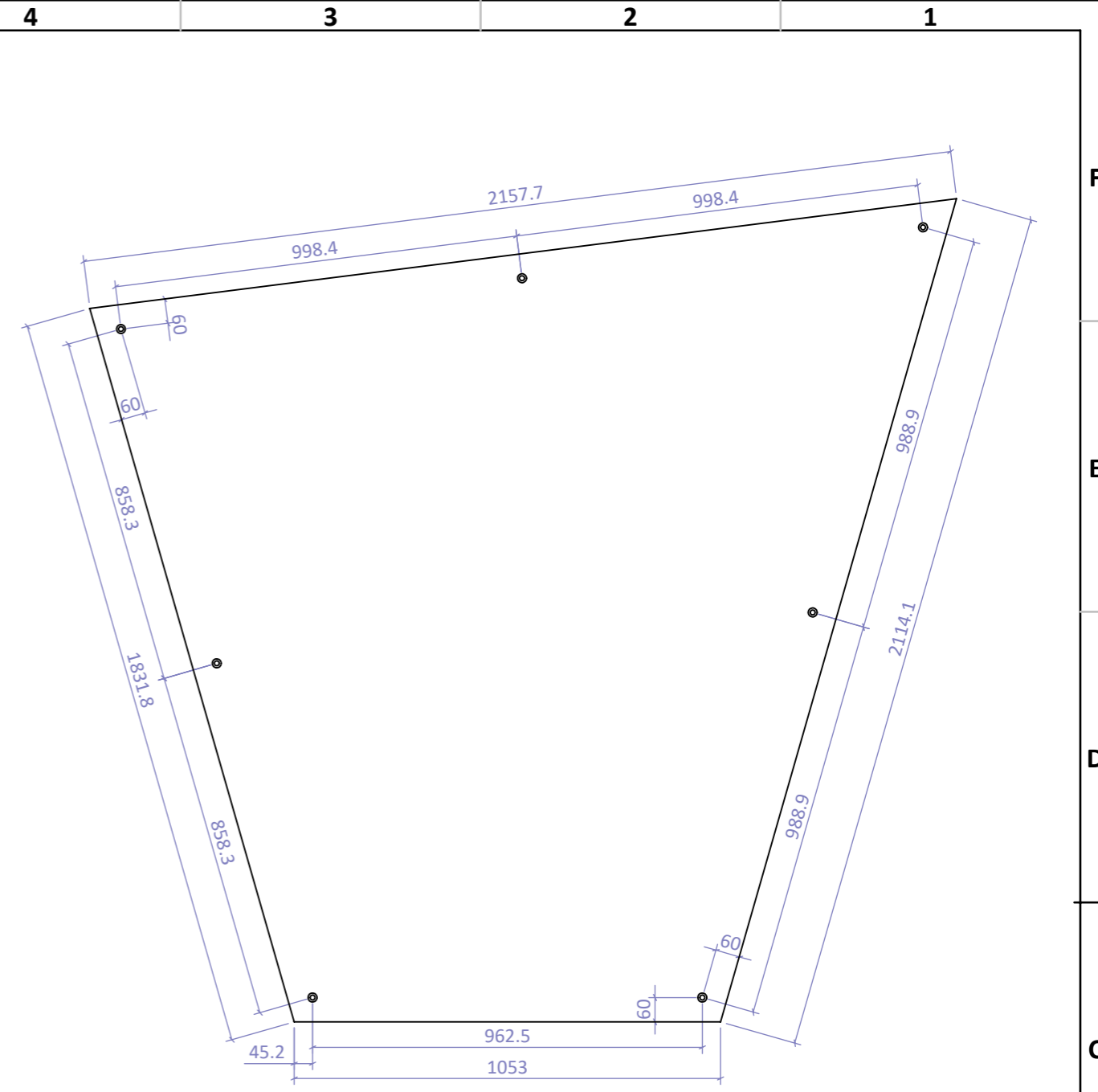
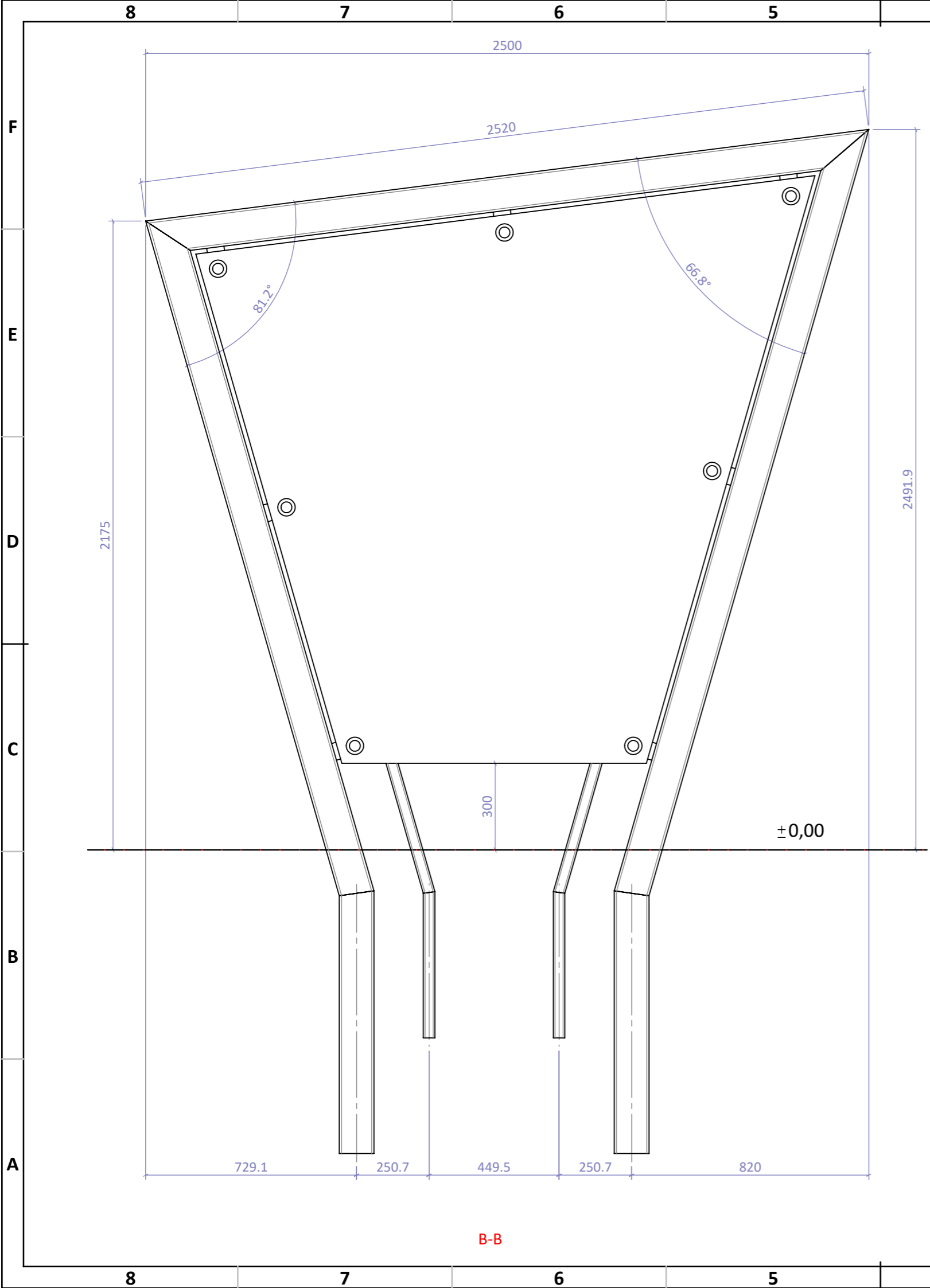

HOL\_CONC\_r-00

-		COATING: HDG, EN-ISO 1461 ;		
 ul. Dąbrowskiego 247/249 93-231 Łódź Polska tel: (+48) 42 670-75-55 Fax: (+48) 42 670-81-80 e-mail: sawo@sawo.com.pl		Drawn by <b>H.Hofer</b> 30.04.2021	Verified by <b>SAWO</b> 30.04.2021	Approved by - -
		Tolerances: acc. to ISO 13920 DH		Date 30.04.2021
Proj.  Name	<b>WIDOK A - SZKŁO</b>		Drawing number <b>HOL</b>	
Scale 1:20			Unit mm	Size A3
			Rev 0	Sheet 7/10



-		COATING: HDG, EN-ISO 1461 ;		
 ul. Dąbrowskiego 247/249 93-231 Łódź Polska tel: (+48) 42 670-75-55 Fax: (+48) 42 670-81-80 e-mail: sawo@sawo.com.pl		Drawn by <b>H.Hofer</b> 30.04.2021	Verified by <b>SAWO</b> 30.04.2021	Approved by - -
		Tolerances: <b>acc. to ISO 13920 DH</b>		Date <b>30.04.2021</b>
Proj. 	Name <b>WIDOK B</b>	Drawing number <b>HOL</b>	Unit <b>mm</b>	Size <b>A3</b>
Scale <b>1:15</b>			Rev <b>0</b>	Sheet <b>8/10</b>

HOL\_CONC\_r-00



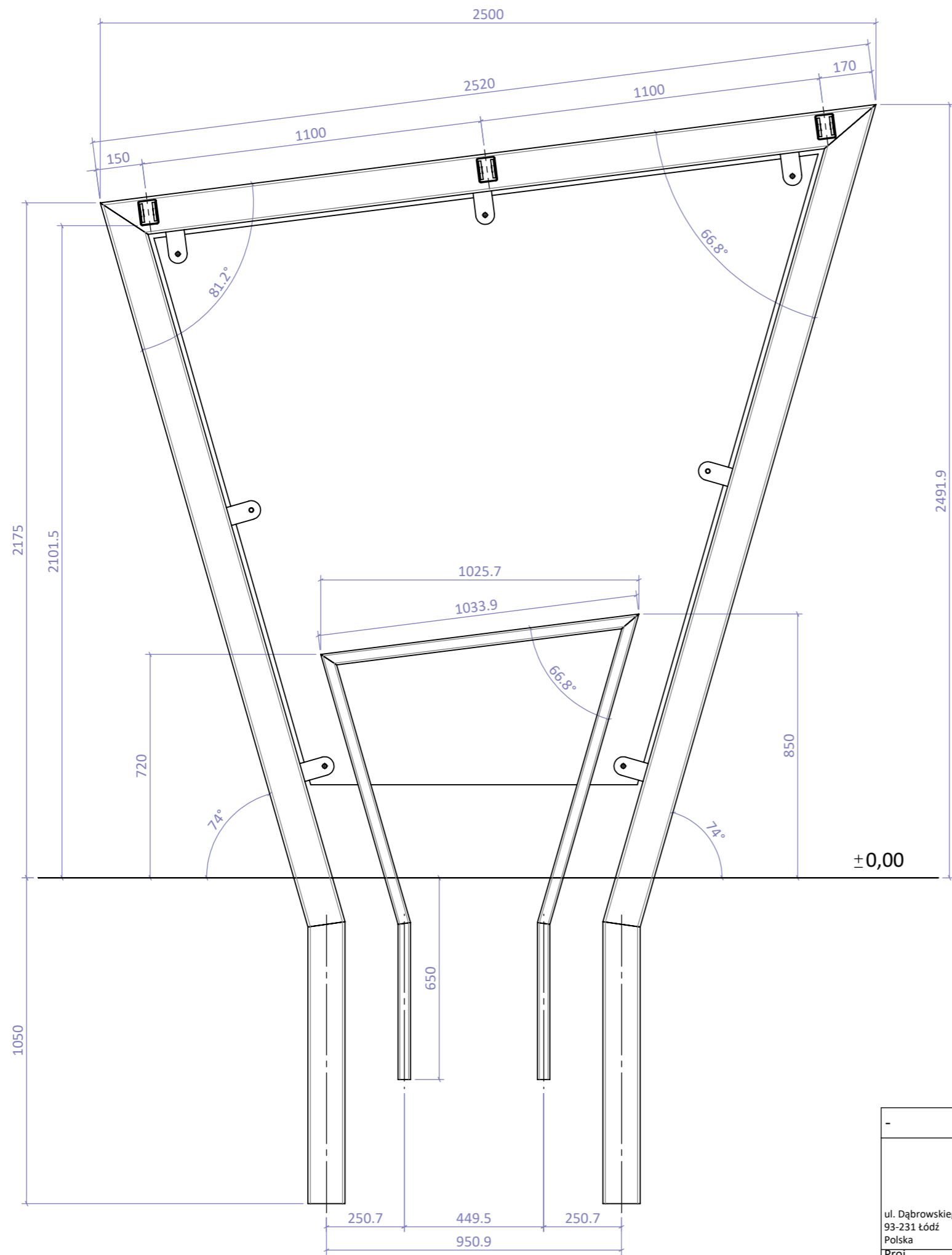

-		COATING: HDG, EN-ISO 1461 ;		
		Drawn by <b>H.Hofer</b> 30.04.2021	Verified by <b>SAWO</b> 30.04.2021	Approved by -
		Tolerances: acc. to ISO 13920 DH		Date 30.04.2021
Proj. Scale 1:15	Name <b>WIDOK B1</b>	Drawing number <b>HOL</b>		Unit mm
				Size A3
				Rev 0
				Sheet 9/10